

# NEW APPROACH FOR POINT-TO-POINT DISTANCE CALIBRATION IN TERRESTRIAL LASER SCANNER

Vitor Camargo Nardelli  
vitor.nardelli@senairs.org.br

Márcio Piecha dos Santos  
marcio.piecha@senairs.org.br

Alex Krumpfenauer  
alex.krumpfenauer@senairs.org.br

Aachen, DE | September 16 – 18

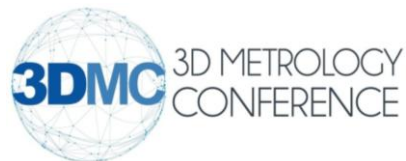

# Largest Private Research and Development Network in Brazil

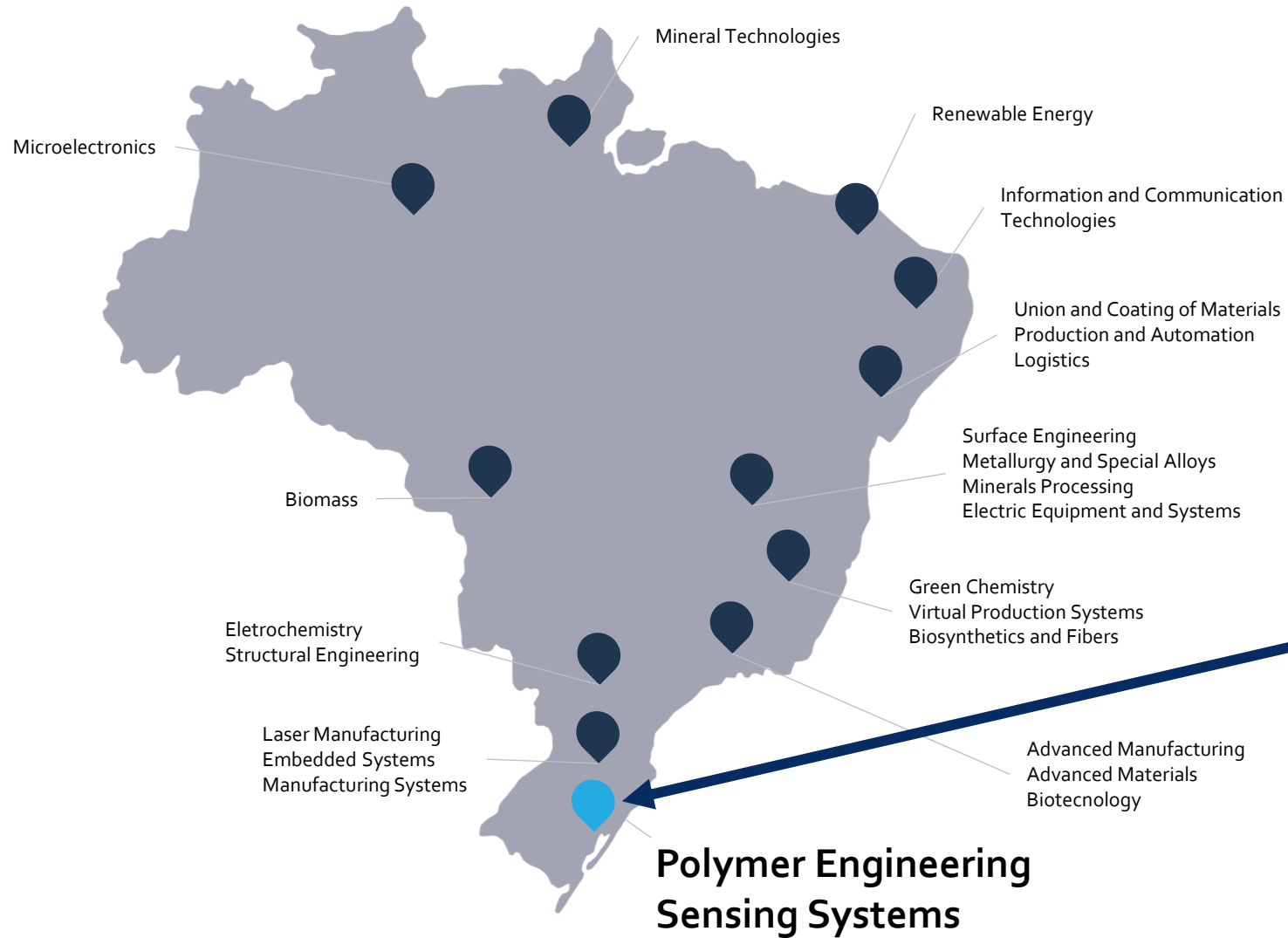

**Sistema**  
**FIERGS**  
SESI | SENAI | IEL | CIERGS





# 3D Metrology



3D Scanning



Digitalization



Large-volume  
measurement



Evaluation of accuracy and  
precision in measurement systems



Comparison of measurement  
methods



Laser Tracker



Total Station



Laser Scanner



Photogrammetry



# Introduction

# Reference Standard

- Test method for obtaining the point-to-point distance measurement errors for medium-range 3D imaging systems.
- Evaluate or to verify the point-to-point distance measurement performance of medium-range 3D imaging systems.
- This test method may be used to compare performance among different instruments.



# Reference Standard ASTM 3125

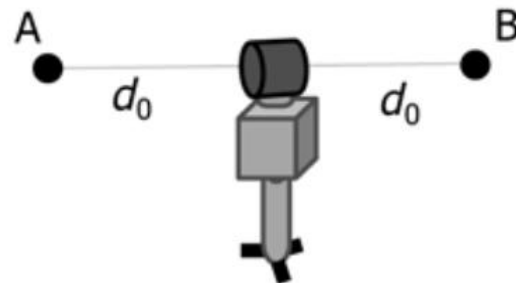
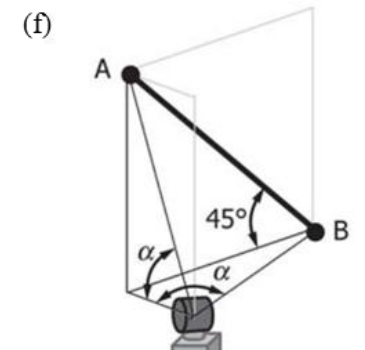
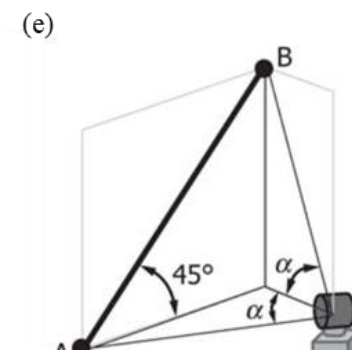
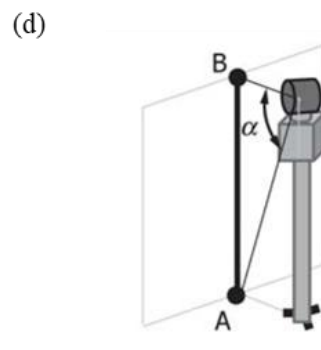
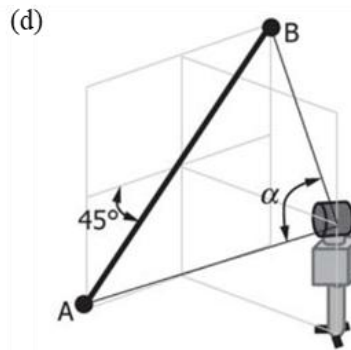
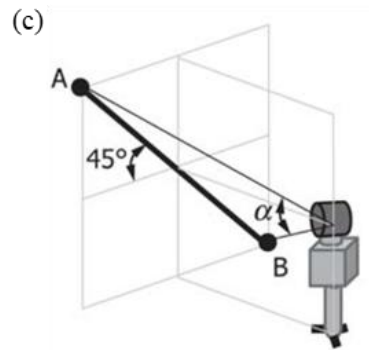
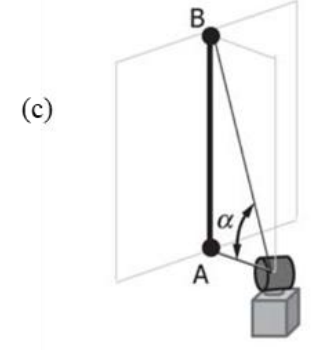
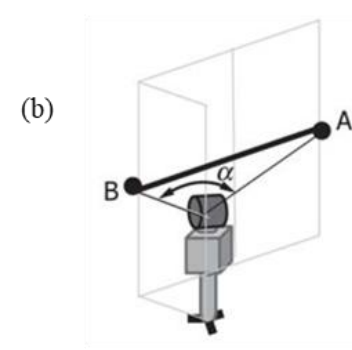
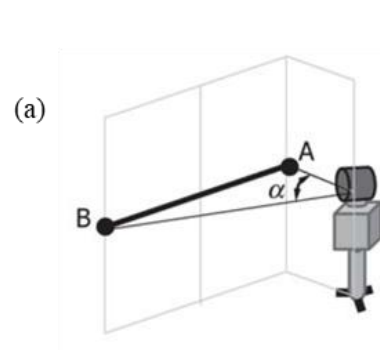
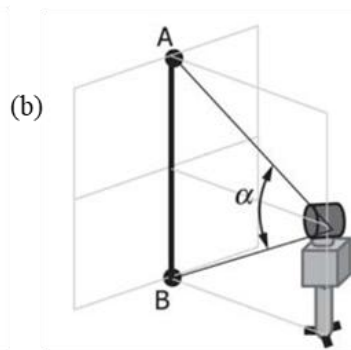
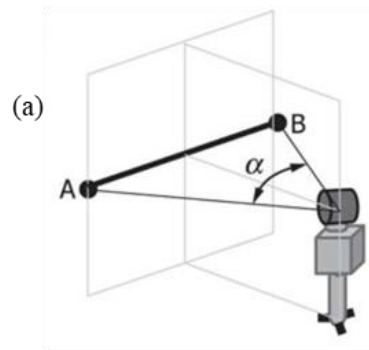

# Reference Standard ASTM 3125 – Set up

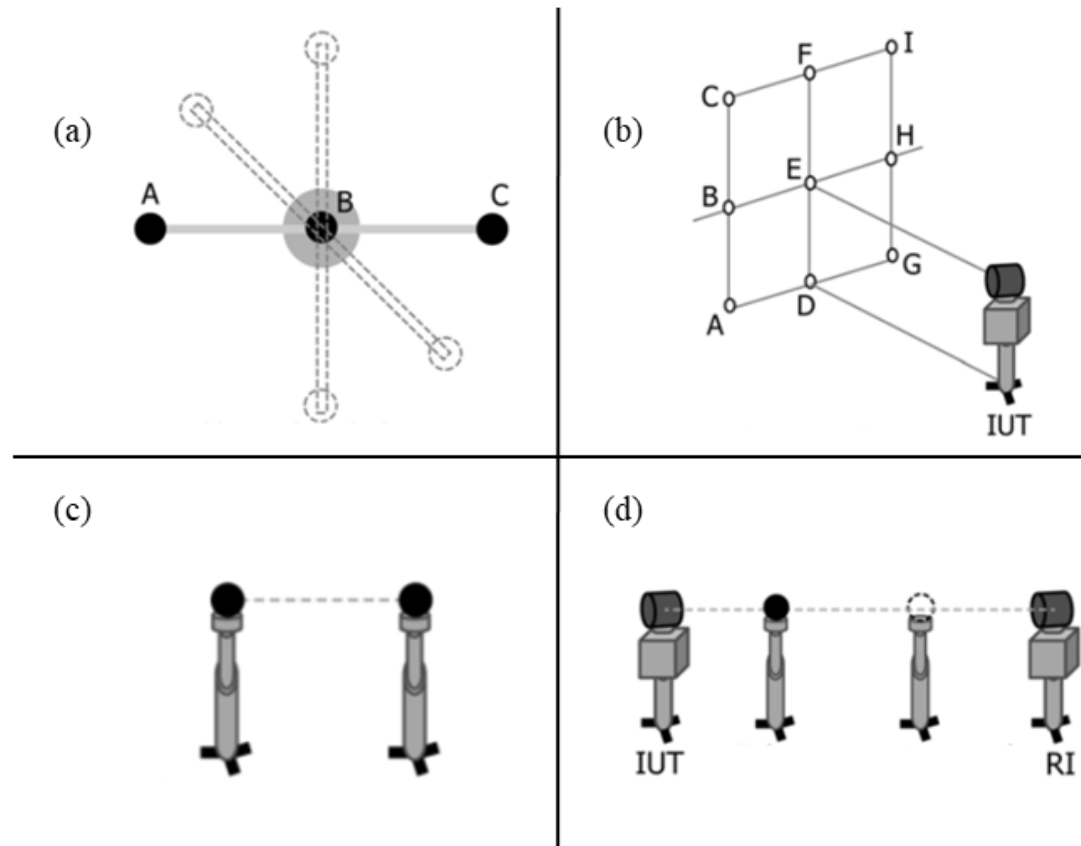

ASTM E 3125, 2017

Point-to-Point Distance Test

Set up 0° and 90° (laser scanner head position)



# Experimental Approach

# New Approach for Point-to-point Distance Calibration

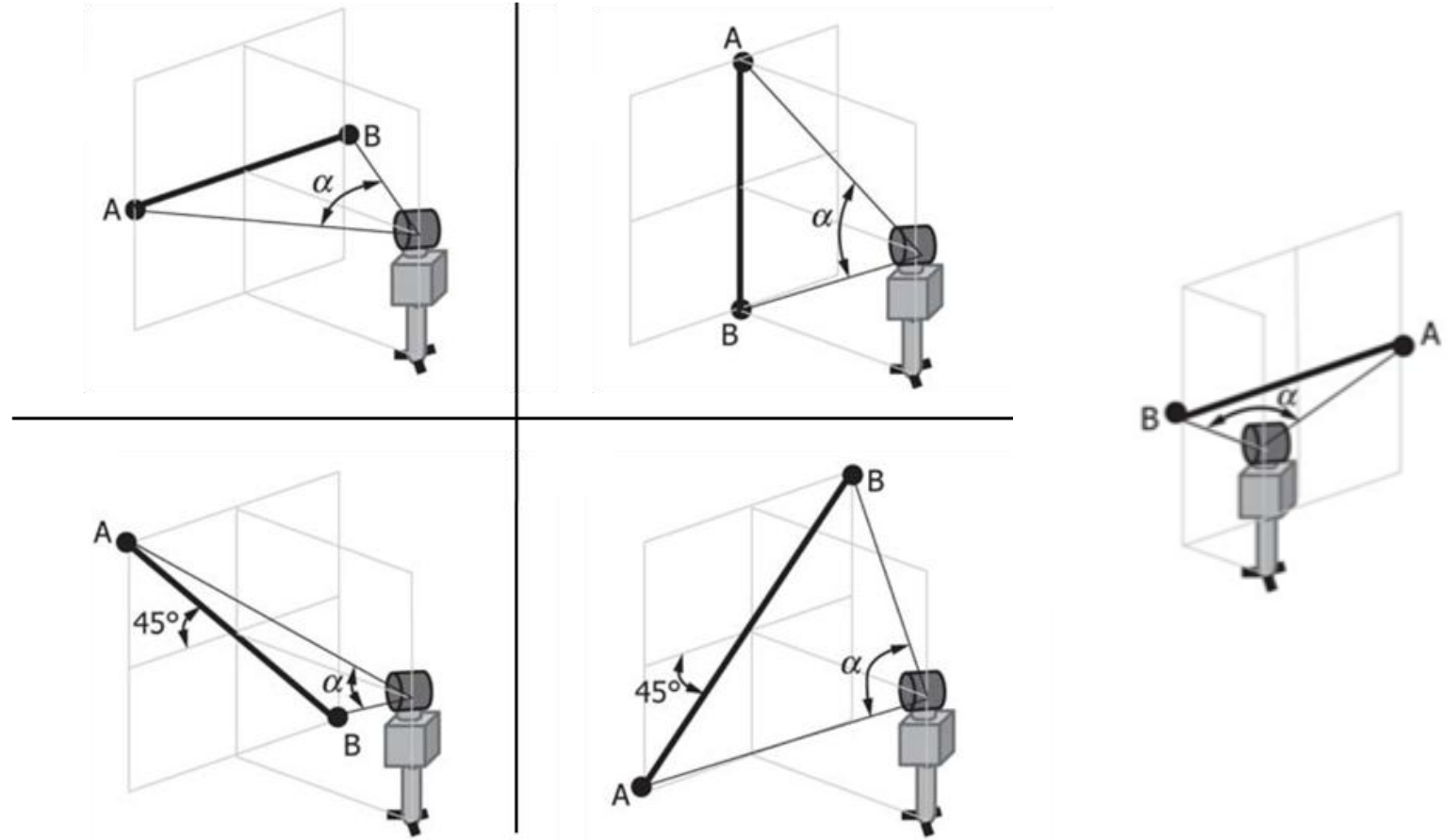
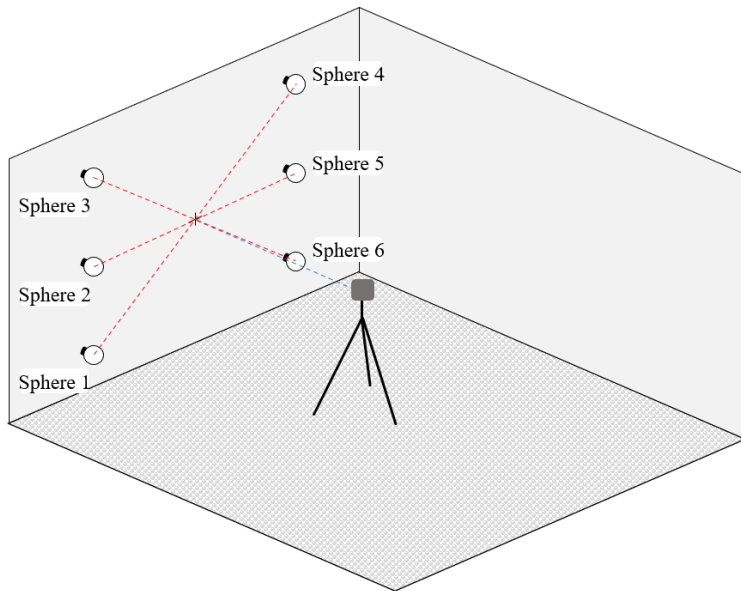
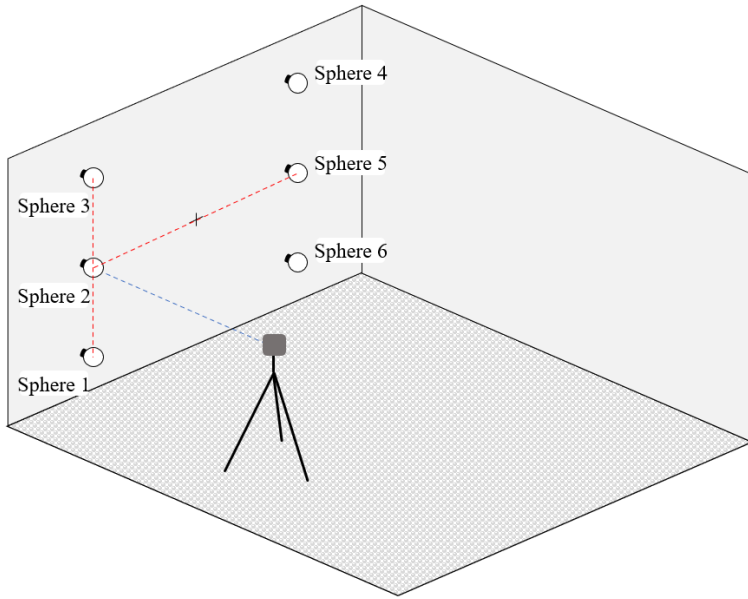

# New Approach for Point-to-point Distance Calibration

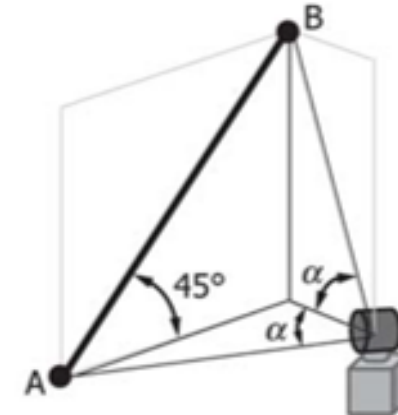
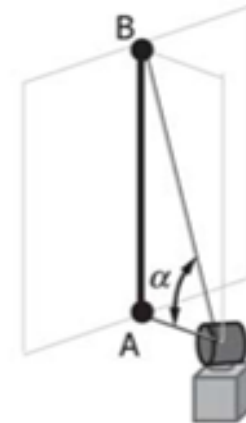
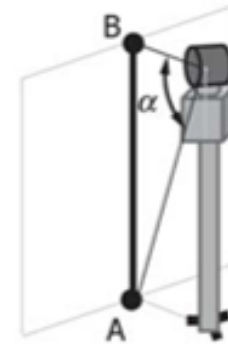
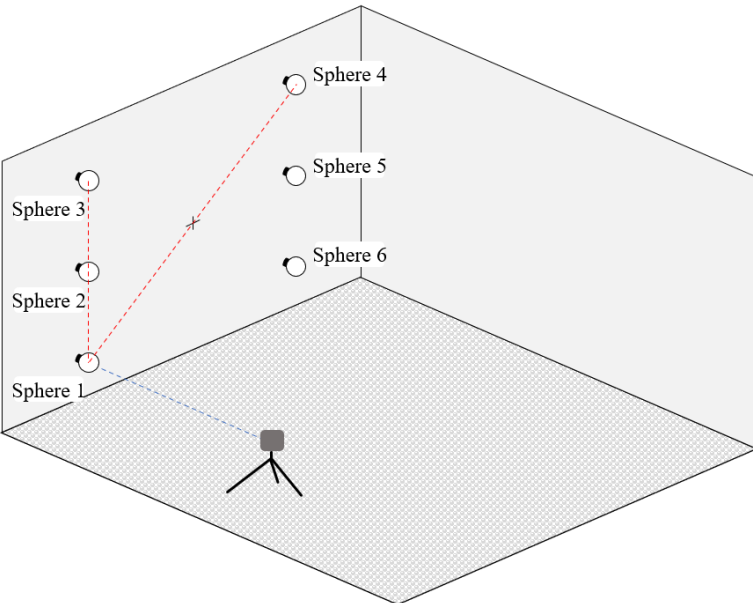
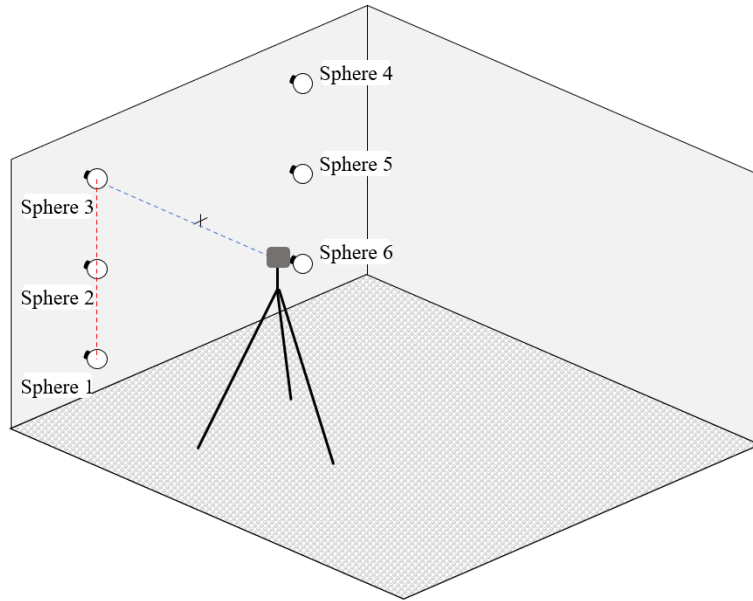

# New Approach for Point-to-point Distance Calibration

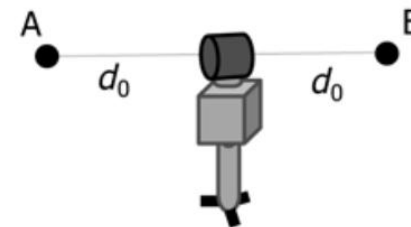
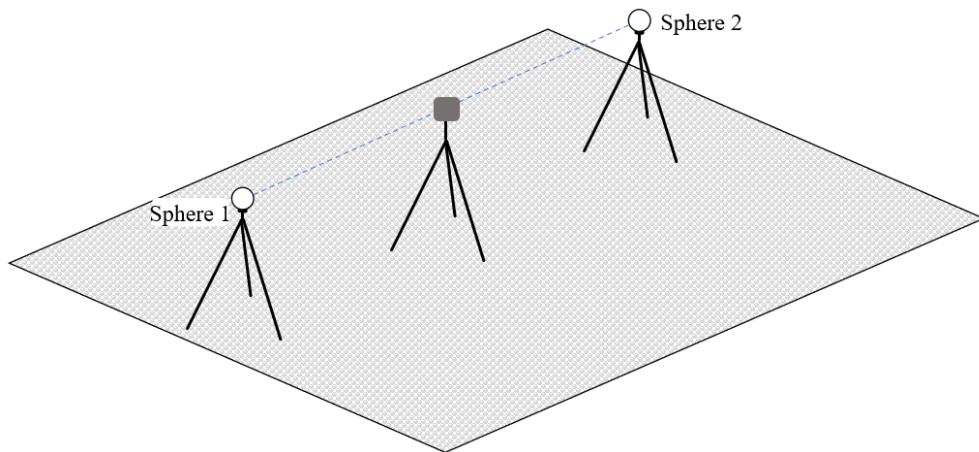
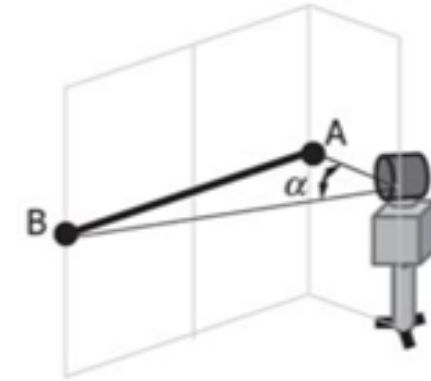
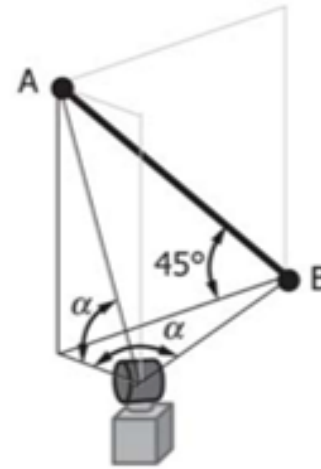
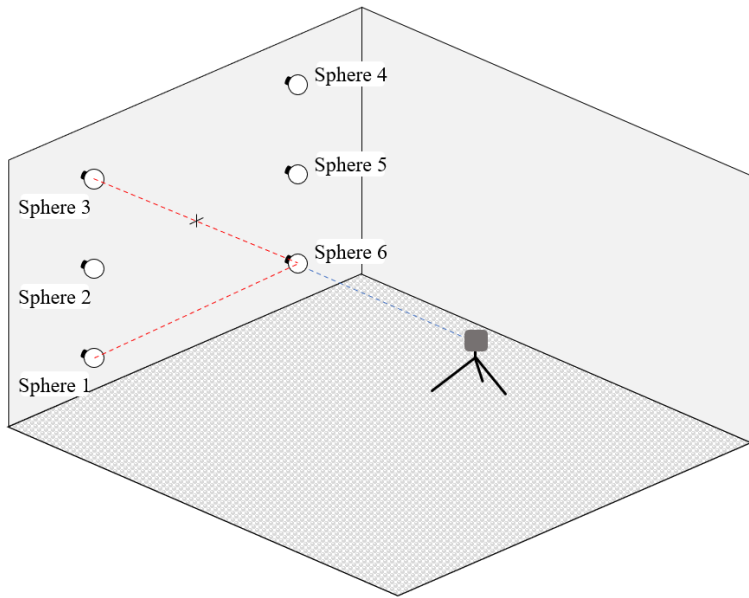

# New Approach for Point-to-point Distance Calibration

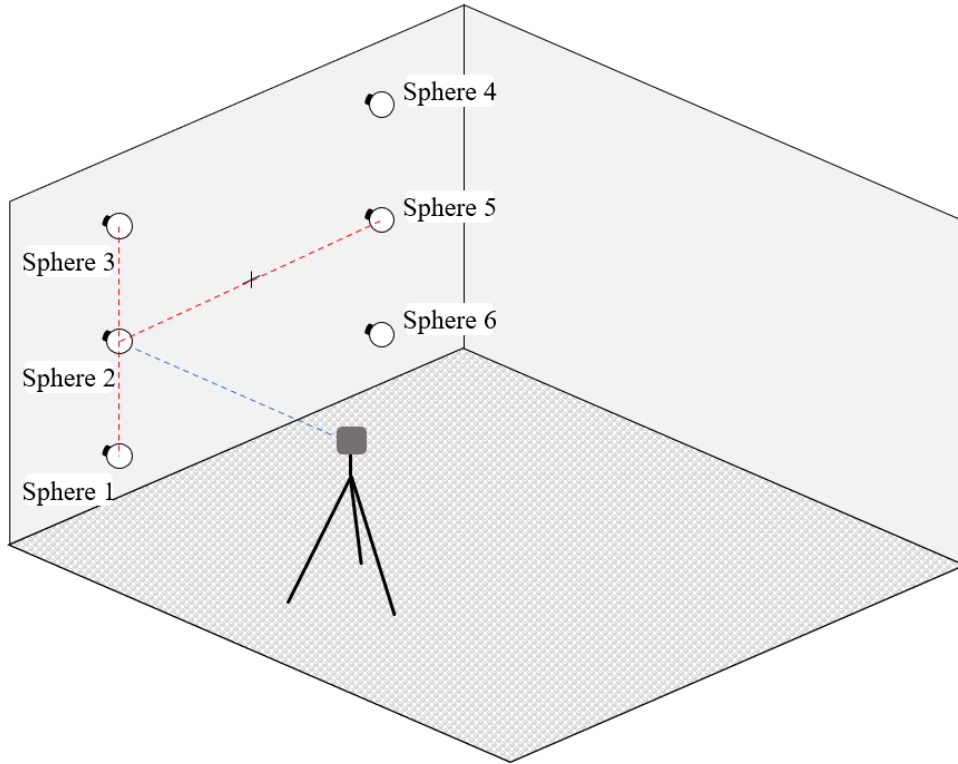

Two columns with 3 spheres each



3D METROLOGY  
CONFERENCE

Aachen, DE  
September 16 – 18

**Sistema**  
**FIERGS**  
SESI | SENAI | IEL | CIERGS

# Object of Study

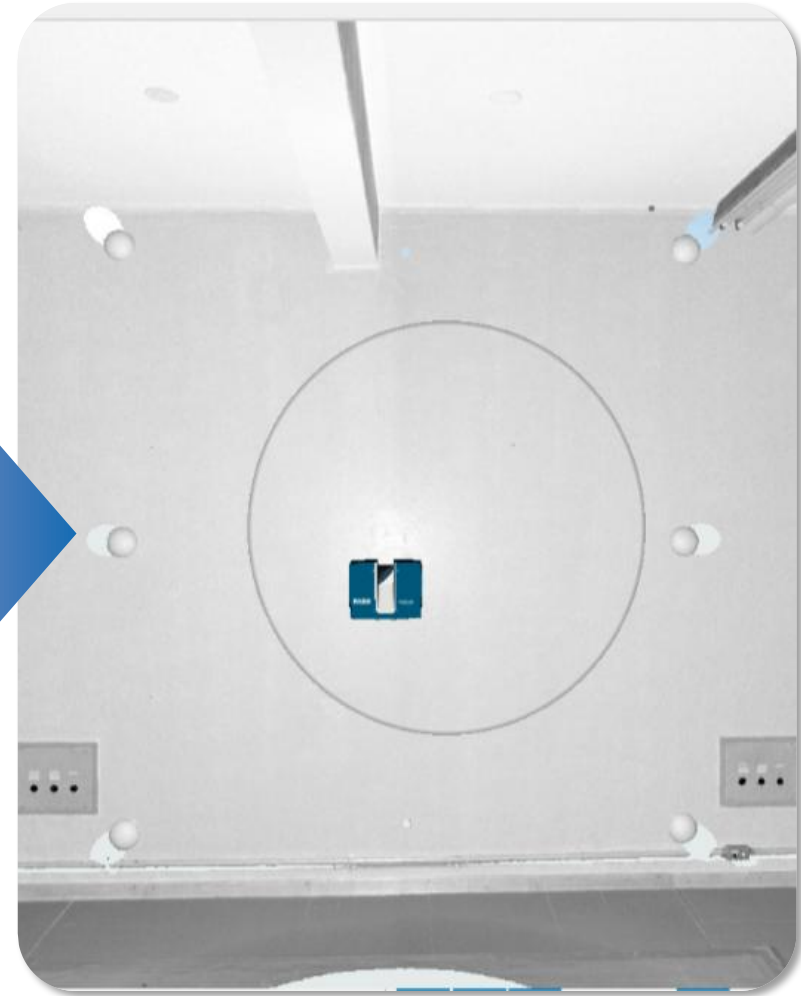
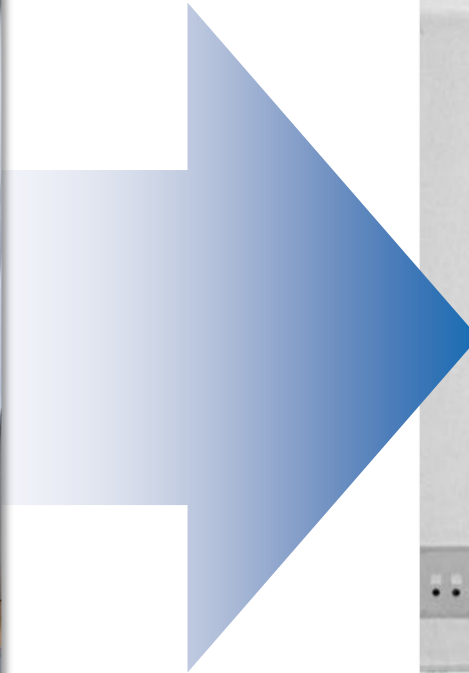

3D METROLOGY  
CONFERENCE

Aachen, DE  
September 16 – 18

**Sistema**  
**FIERGS**  
SESI | SENAI | IEL | CIERGS

# Reference Artifacts and Equipments



Leica Laser Tracker AT960 + T-Scan

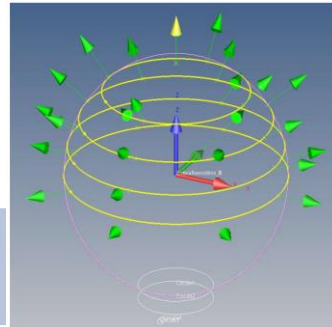

Ø150 mm Spherical Artifact

Arrangement of Spheres

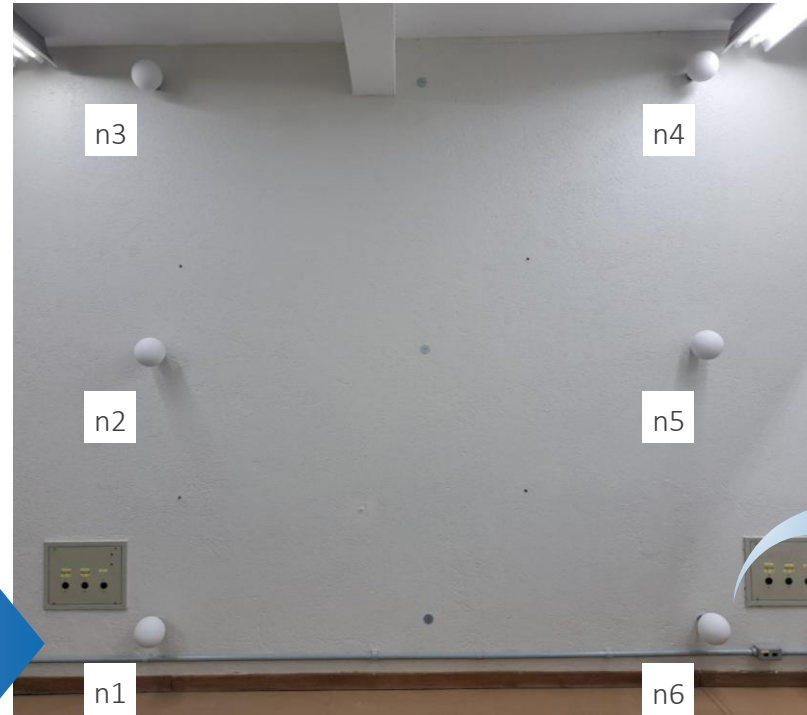

Distance between	Mean (mm)	Measurement Uncertainty (mm)	<i>k</i> Coverage Factor	Degrees of Freedom $v_{eff}$
Sphere 1 to 3	2805.89	0.46	2.00	$\infty$
Sphere 1 to 4	3970.22	0.56	2.00	$\infty$
Sphere 1 to 6	2813.27	0.46	2.01	484
Sphere 2 to 5	2809.10	0.49	2.00	$\infty$
Sphere 3 to 6	3969.67	0.43	2.00	$\infty$
Inside Test	4001.17	0.49	2.00	$\infty$

Reference Distance between Sphere Pairs



3D METROLOGY CONFERENCE

Aachen, DE  
September 16 – 18



# Uncertainty Component Analysis

Analyzing uncertainty components helps to understand how to minimize undesirable effects

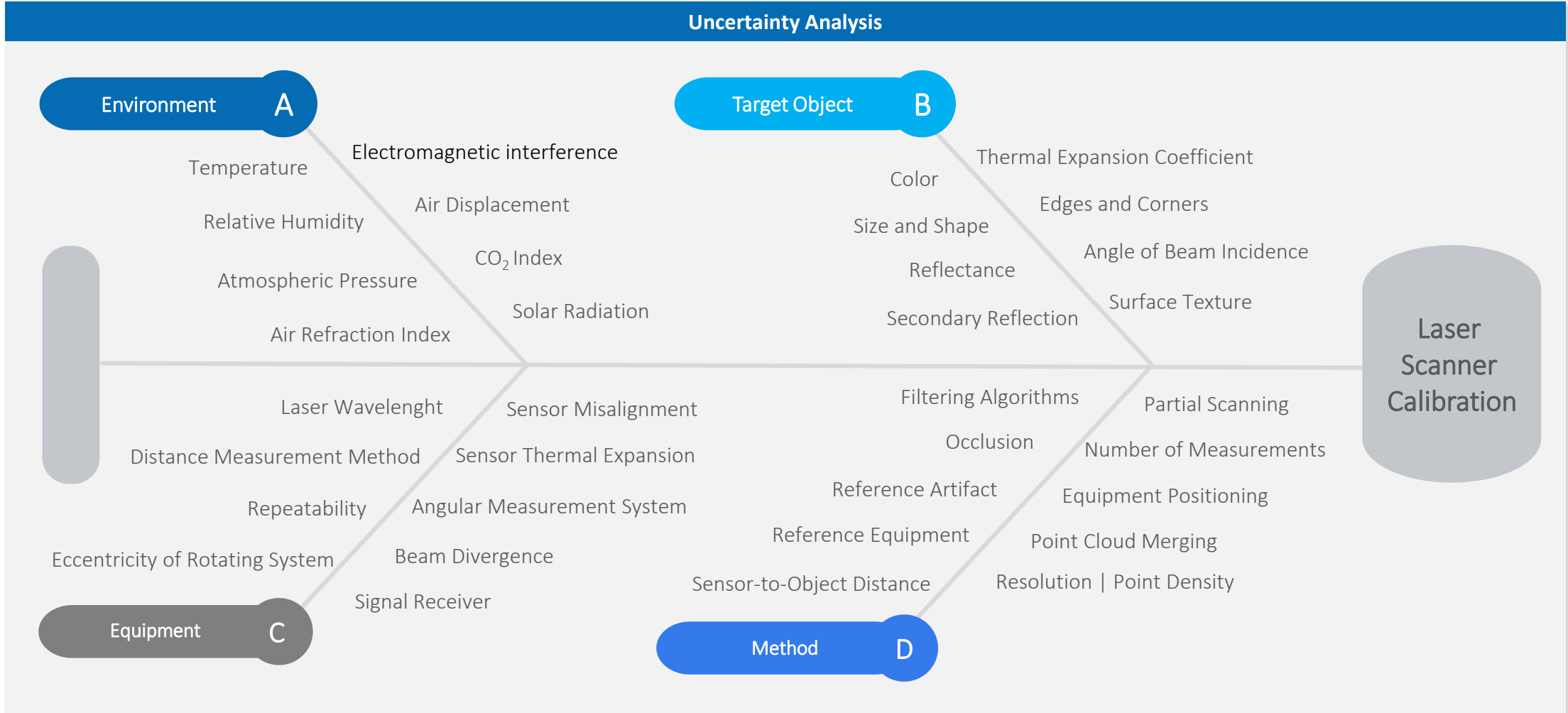



# Results

# Measurement Results

## Point-to-point Measurement Results – 0° Position

● Symmetric Position   ■ Asymmetric Position   ◆ Inside Position   | Measurement Uncertainty

— Maximum Permissible Error

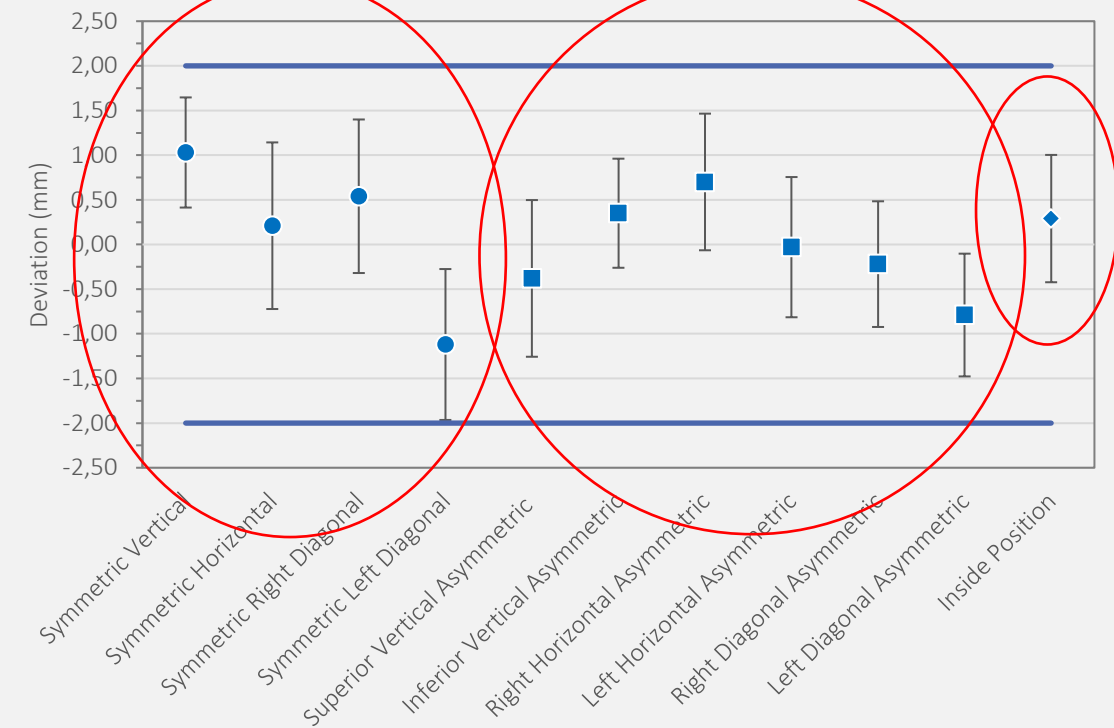

The largest error ( $1.33 \pm 0.63$ ) mm was obtained in the vertical symmetric measurement, in which the distance between the spheres is 2805.89 mm. In percentage terms, the largest error is ( $0.047 \pm 0.22$ ) %.

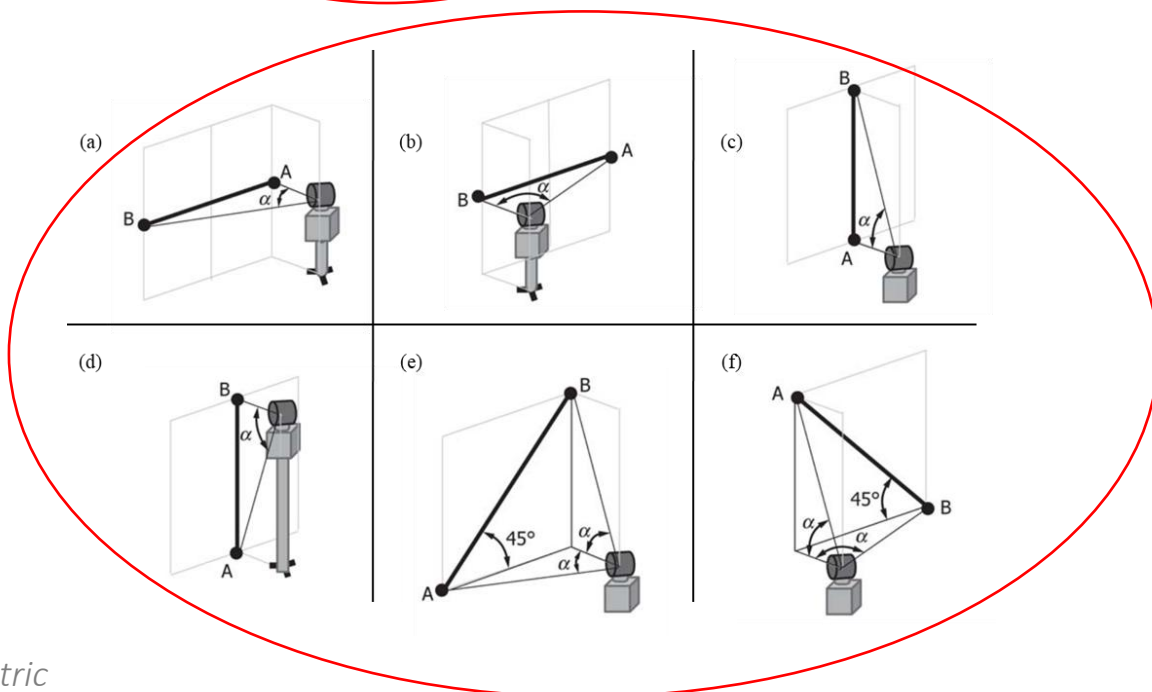
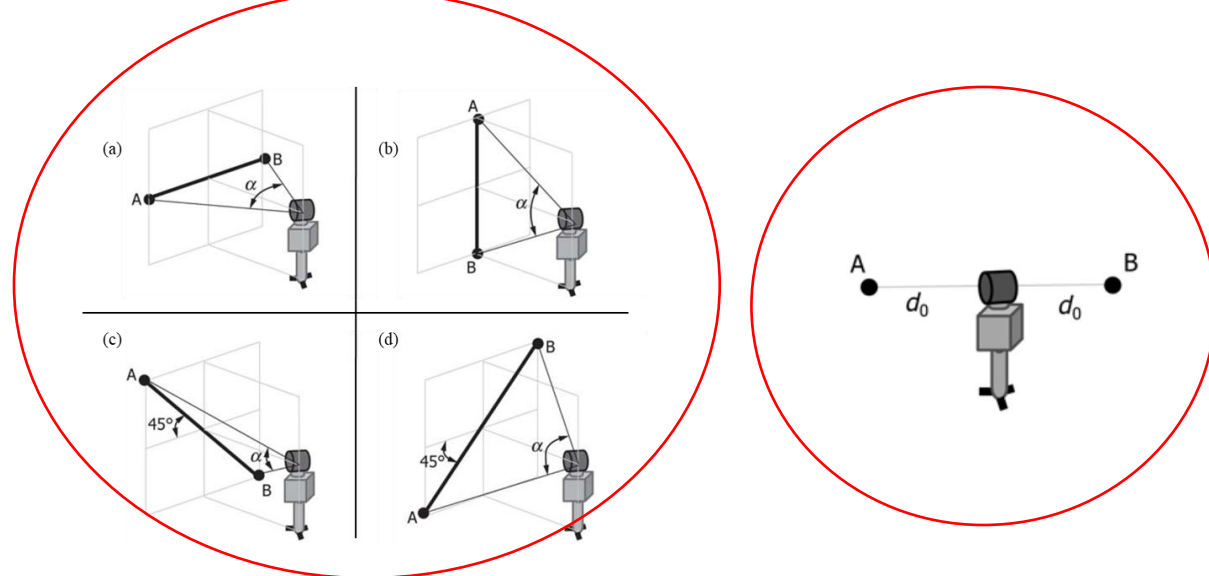

# Measurement Results



## Point-to-point Measurement Results – 90° Position

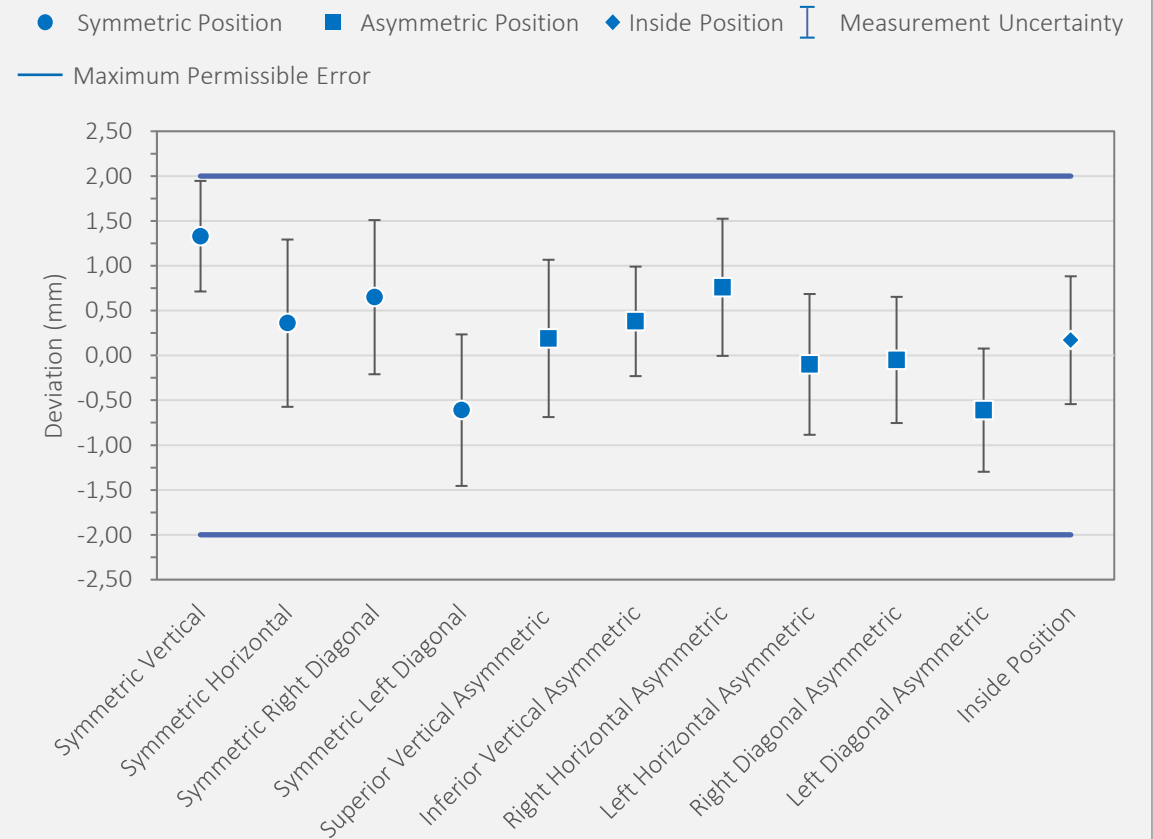

The largest error ( $1.33 \pm 0.63$ ) mm was obtained in the vertical symmetric measurement, in which the distance between the spheres is 2805.89 mm. In percentage terms, the largest error is ( $0.047 \pm 0.22$ ) %.

# Measurement Results

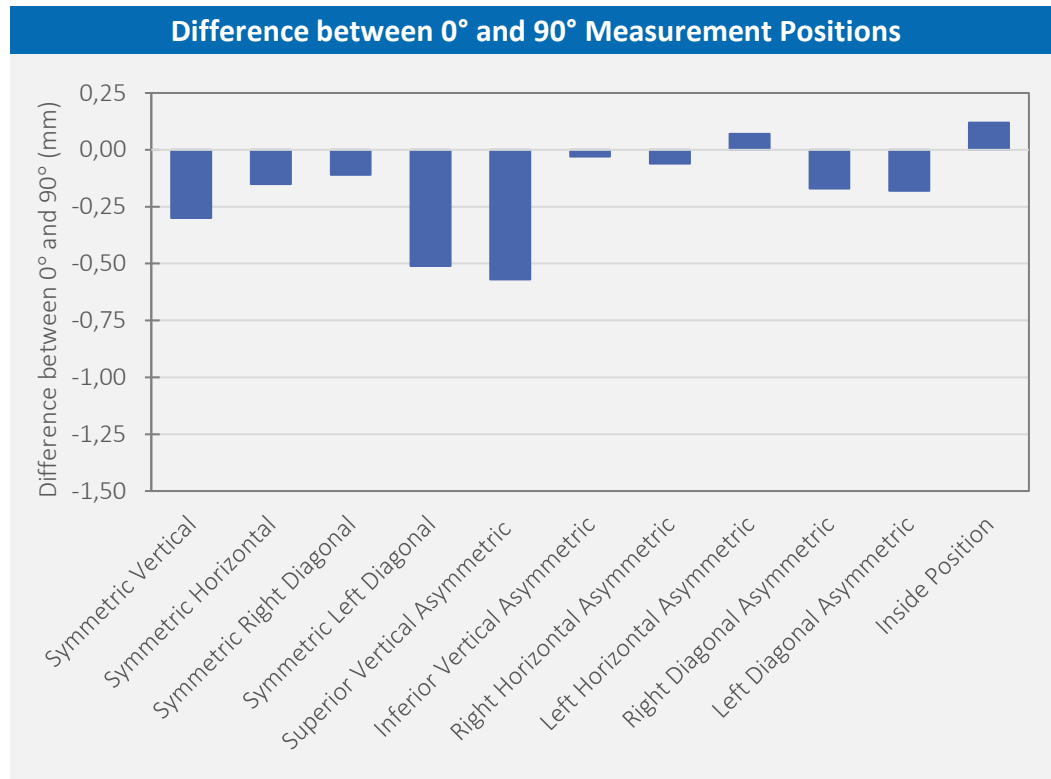

The symmetric and asymmetric characteristics, with the exception of the left horizontal asymmetric one, show negative deviations. This represents a distortion in the ideally spherical measurement volume of the laser scanner.

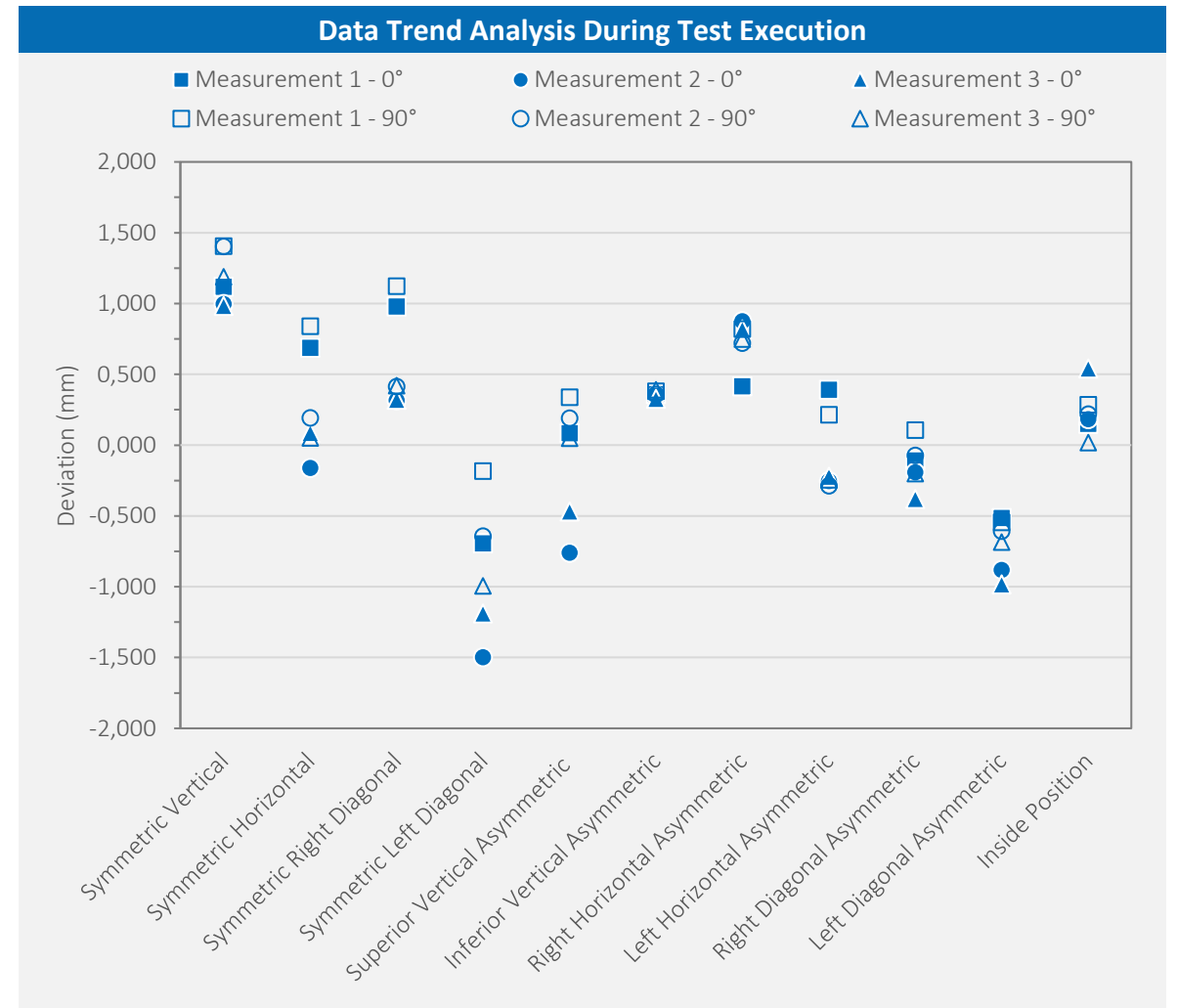

# Uncertainty Measurement Budget

Input Quantity	Value (mm)	Probability Distribution	Divider	Sensitivity Coefficient	Standard Uncertainty (mm)	Degrees of Freedom $v_{eff}$
Repeatability	0.437	<i>t-student</i>	$\sqrt{n}$	1	0.252	$n-1$
Reference Distance Measurement Uncertainty	0.49	Normal	2.00	1	0.245	$\infty$
Sphere n1 Roundness	0.644	Rectangular	$2\sqrt{3}$	1	0.186	$\infty$
Sphere n3 Roundness	0.565	Rectangular	$2\sqrt{3}$	1	0.163	$\infty$
			<b>Combined Standard Uncertainty</b>	<b><i>k</i> Coverage Factor</b>	<b>Degrees of Freedom <math>v_{eff}</math></b>	<b>Expanded Uncertainty (95.45%)</b>
			0.4301	2.17	16	<b>0.9 mm</b>

Uncertainty Budget for 0° Symmetric Horizontal Position

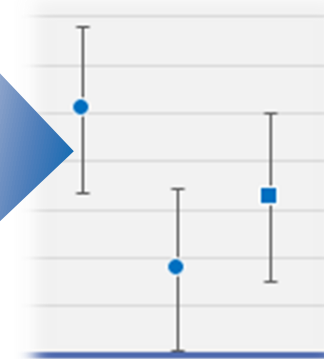
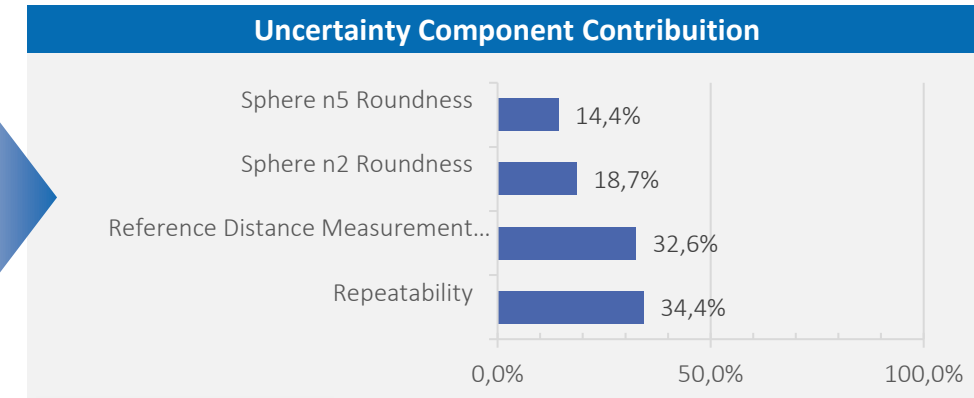

The uncertainty budget details the contribution of each source of variability to the combined standard uncertainty. From this, the expanded uncertainty is calculated for a 95.45% confidence level, defining the interval wherein the true value of the measurand is expected to lie. This interval is visually represented by the uncertainty bars in the chart.

# Concluding remarks

- Optimized scanning positions led to reduced calibration time and cost.
- Robust and Effective Method: Enabled detailed performance analysis of the equipment.
- Comprehensive Error Mapping: Identified error distribution across the laser scanner's spherical measurement volume.
- Measurement Uncertainty Estimation: Provided insights into influencing factors and their significance.
- Enhanced Metrological Understanding: Deepened knowledge of the scanner's behavior under real conditions.
- Standardization Potential: Supports the development of a standardized calibration and usage process.

# Thank you!

Vitor Camargo Nardelli  
vitor.nardelli@senairs.org.br